

SPECIFICATION FOR APPROVAL
AC/DC ADAPTOR

CUSTOMER SPEC: INPUT: 100-240V AC 50/60Hz OUTPUT: 12V DC 1.5A

CUSTOMER DWG./PART NO. _____

KTEC PART NO. KSA-18W-120150VU (PAHS 6P NP REACH ROHS PROP65)

SAMPLE NO: S99333 REV.: A ISSUE DATE: 2024-05-21

PRODUCT NO: KS240392

Unit Color: Black White

APPROVED SIGNATURES/客户确认		
核准/APPROVED BY	审核/CHECKED BY:	检测/TESTED BY:

Manufacturer/制造商			
业务/SALES	品管/QE	核准/APPROVED BY	制样/MADE BY
TAI	徐海鑫	贺洪明	冯连连

KTEC GLOBAL CO., LTD.
KTEC 冠德国际科技股份有限公司

深圳研发中心地址: 中国广东省深圳市光明新区马田街道办合水口社区第四工业区中鹏程大厦四楼
ADD: 4F Zhong PengCheng Building, No.4 Industrial Park, He shuikou Community, Matian street,
Guangming New Zone, Shenzhen City, guangdong province, China

台北总部地址: 235024 新北市中和区中板路 23 号 9 楼
ADD: 9F., No. 23, Zhongban Rd., Zhonghe Dist., New Taipei City 235024

柬埔寨制造据点: 柬埔寨茶胶省当谷县本布乡站波村(三号公路 66 公里处)
ADD: Phum Chornpul, Khum P'pel, Srok Tramkork, Takeo Province, Kingdom
of Cambodia(66KM,National Broad Road)

TEL:86-755-27160388 FAX:86-755-27160145
[Http://www.twktec.com](http://www.twktec.com)



KTEC 冠德國際科技
KTEC GLOBAL CO., LTD.

Switching power supply specification(class B)

KTEC P/N:	PRODUCT NO.:	CUSTOMER P/N:
KSA-18W-120150VU	KS240392	

1 GENERAL	4
1.1 Description.....	4
2 INPUT REQUIREMENTS	4
2.1 Input Conditions.....	4
2.2 AC Inrush Current.....	4
3 OUTPUT REQUIREMENTS	4
4 MECHANICAL	5
4.1 Enclosure and Layout.....	5
4.2 Input and Output Configuration.....	5
5 REGULATORY COMPLIANCE	6
5.1 EMC Specifications.....	6
5.1.1 Radiated and Conducted Emission.....	6
5.2 Immunity.....	6
5.2.1 Electrostatic Discharge Immunity	6
5.2.2 Radiated Field Immunity	6
5.2.3 Fast Transient Immunity	6
5.2.4 Surge Immunity	6
5.3 Safety Requirements and Certification.....	7
5.3.1 Regulatory Standard.....	7
5.3.2 Additional Safety Requirements.....	7
6 ENVIRONMENTAL REQUIREMENTS	7
6.1 Temperature.....	7
6.2 Relative Humidity.....	7
7 APPEARANCE DRAWING: (Unit: mm)	8
8 NAME PLATE:	9
9 DIMENSION OF OUTPUT PLUG & DC CORD (Unit: mm)	10
10 PACKING (Unit: mm)	11

TITLE:		REVISION: A	DRAWING NO.:	
PREPARED : 余国娟	CHECKED: 林学贤 林英青	APPROVED : 贺洪明	DATE: 2024-05-21	PAGE: 3 OF 11



Switching power supply specification(class B)

KTEC P/N:	PRODUCT NO.:	CUSTOMER P/N:
KSA-18W-120150VU	KS240392	

1 GENERAL

1.1 Description

This specification defines the performance characteristics for a class II adapter, single-phase 18.0 watts. Single output level power supply.

- Simple design philosophy.
- Reliability level of 50K hours MTBF @ 25°C (rated input voltage, and using the Telcordia SR-332 Issue 3 method).
- DC output voltage must be Safe Extra Low Voltage (SELV) & Limited Power as defined by IEC62368-1.
- Cooling: natural convection.

2 INPUT REQUIREMENTS

2.1 Input Conditions

The supply shall operate over the voltage ranges as follows:

Rated input voltage	100-240Vac
Operating range	90-264Vac
Rated input frequency	50/60Hz +/- 3Hz
Rated input current	0.5A Max.
Power consumption (no-loading)	0.1W Max.
Primary current protection	An adequate internal fuse on the AC input line is provide.
Configuration	<u>2</u> Conductor

2.2 AC Inrush Current

No damage shall be occurred and the input fuse shall not be blown up nominal input voltage full load 25°C cold start.

3 OUTPUT REQUIREMENTS

3.1	Nominal DC output voltage	+12.0V
3.2	Minimum load current	0A
3.3	Rating load current	1.5A
3.4	Peak load current	/
3.5	Rating output power	18.0W
3.6	Line regulation	The line regulation is less than <u>±5%</u> while measuring at rated load and +/-10% of input voltage changing.
3.7	Load regulation	The load regulation for <u>+12.0V</u> is less than <u>+/-5%</u> , at measured output load from 10% to 100% rated load .

TITLE:		REVISION: A	DRAWING NO.:	
PREPARED : 余国娟	CHECKED: 林学贤 林英青	APPROVED : 贺洪明	DATE: 2024-05-21	PAGE: 4 OF 11



Switching power supply specification(class B)

KTEC P/N:	PRODUCT NO.:	CUSTOMER P/N:
KSA-18W-120150VU	KS240392	

3.8	Peak load regulation	The peak load regulation for +12.0V is less than <u> / </u> , at measured output load from 30% to 100% rated load.
3.9	Ripple and noise	150 mVp-p Add 0.1uF/50V ceramic capacitor and 10uF/50V aluminum electrolytic capacitor across the output terminal. Measured with 20MHz Bandwidth Oscilloscope.
3.10	Average efficiency	<u>85%</u> minimum 115V/60Hz and 230V/50Hz, output current from 100%, 75%, 50%, 25%.
3.11	Turn on delay time	<u>3000 mS</u> max at nominal input AC voltage and full load.
3.12	Rise time	The supply shall have a start-up rise time of less than <u>20 mS</u> to rise to within regulation limits for all DC outputs.
3.13	Hold up time	<u>8 mS</u> minimum at nominal input 100V AC minimum voltage and full load.
3.14	Output over-shoot	Less than <u>10%</u> of nominal voltage value.
3.15	LED indication function	/
3.16	Protection function	
	Over-voltage protection	The output voltage shall be clamped by internal protection.
	Short-circuit protection	The adapter shall not be damaged by short the DC output to Ground. The adapter shall resume normal operation when a short circuited fault condition is removed.
	Over current protection	The output shall be protected against the over current conditions.

4 MECHANICAL

4.1 Enclosure and Layout

Plastic case: UL94V-0
 Weight : /g (Max)
 Dimensions: 70*30*40mm
 Colour : WHITE(WT-07)

4.2 Input and Output Configuration

Input pin: US Pin
 Output connector : DC plug type: : 5.5*2.5*11mm “Fork and Groove”
 Polarity: Center”+”
 Cable: 1.8M VW-1 80°C 300V 2468 22AWG 2C WHITE(WT-07)
(PAHS 6P NP REACH ROHS PROP65)

TITLE:		REVISION: A	DRAWING NO.:	
PREPARED : 余国娟	CHECKED: 林学贤 林英青	APPROVED : 贺洪明	DATE: 2024-05-21	PAGE: 5 OF 11



Switching power supply specification(class B)

KTEC P/N:	PRODUCT NO.:	CUSTOMER P/N:
KSA-18W-120150VU	KS240392	

5 REGULATORY COMPLIANCE

5.1 EMC Specifications

The external power supply must meet all specification in this section. It is required that the external power supply work closely with the customer's equipment in order to get the best EMC solution.

5.1.1 Radiated and Conducted Emission

FCC part 15: Class B for radiated and conducted emissions.
EN55032, Class B for radiated and conducted emissions.

5.2 Immunity

5.2.1 Electrostatic Discharge Immunity

EN 55035, EN 61000-4-2

- Air Discharge: ±8kv
- Contact Discharge: ±4kv
- Performance Criteria B

Electrostatic-discharge test by contact or air should be conducted with Static-discharge tester, energy storage capacitance of 150pF, and discharge resistance of 330Ω, 8kv air discharge, 4kv contact discharge.

5.2.2 Radiated Field Immunity

EN 55035, EN 61000-4-3

- Frequency Range: 80-1000MHz, still need test singly 1800MHz, 2600MHz, 3500MHz, 5000MHz
- Field Strength: 3 V/m with 80% amplitude modulation of 1kHz
- Performance Criteria A

Radio-frequency electromagnetic field susceptibility test, RS 80-1000MHz, 3V/m, 80%AM(1KHz).

5.2.3 Fast Transient Immunity

EN 55035, EN 61000-4-4

- Power line: 1kv
- Signal line: 0.5kv
- Performance Criteria B

5.2.4 Surge Immunity

EN 55035, EN 61000-4-5

- Line to line: ±1kv
- Line to earth: ±2kv
- + 90°/ -270°

Lightning surge voltage shall be applied in differential and common mode to AC input lines and cross primary AC input and secondary GND.

TITLE:		REVISION: A	DRAWING NO.:	
PREPARED : 余国娟	CHECKED: 林学贤 林英青	APPROVED : 贺洪明	DATE: 2024-05-21	PAGE: 6 OF 11



KTEC 冠德國際科技
KTEC GLOBAL CO., LTD.

Switching power supply specification(class B)

KTEC P/N:	PRODUCT NO.:	CUSTOMER P/N:
KSA-18W-120150VU	KS240392	

5.3 Safety Requirements and Certification

5.3.1 Regulatory Standard

The power supply shall comply with the following international regulatory standards:

for short	Country or Region	Certified Status	Standard
UL	USA	Meet	UL 62368-1
CUL	Canada	Meet	CSA C22.2 NO.62368-1

5.3.2 Additional Safety Requirements

- ⊙ Dielectric Withstand Voltage, Primary(input AC short)-to-Secondary(output DC short): 3000Vac, 5m A, 1 minute.
- ⊙ Insulation Resistance, Input to output: 10MΩ(MIN.) at 500VDC.
- ⊙ Reinforced insulation system, Primary-to-Ground and Primary-to-Secondary.
- ⊙ The leakage current shall not exceed 0.25mA.

6 ENVIRONMENTAL REQUIREMENTS

6.1 Temperature

- ⊙ Operating: 0°C +40 °C
- ⊙ Non-Operating: -20°C +80 °C

6.2 Relative Humidity

- ⊙ Operating: 10%~90% (Non Condensing)
- ⊙ Non-Operating: 10%~90% (Non Condensing)

TITLE:		REVISION: A	DRAWING NO.:	
PREPARED : 余国娟	CHECKED: 林学贤 林英青	APPROVED : 贺洪明	DATE: 2024-05-21	PAGE: 7 OF 11



KTEC 冠德國際科技
KTEC GLOBAL CO., LTD.

Switching power supply specification(class B)

KTEC P/N:

PRODUCT NO.:

CUSTOMER P/N:

KSA-18W-120150VU

KS240392

7 APPEARANCE DRAWING: (Unit: mm)

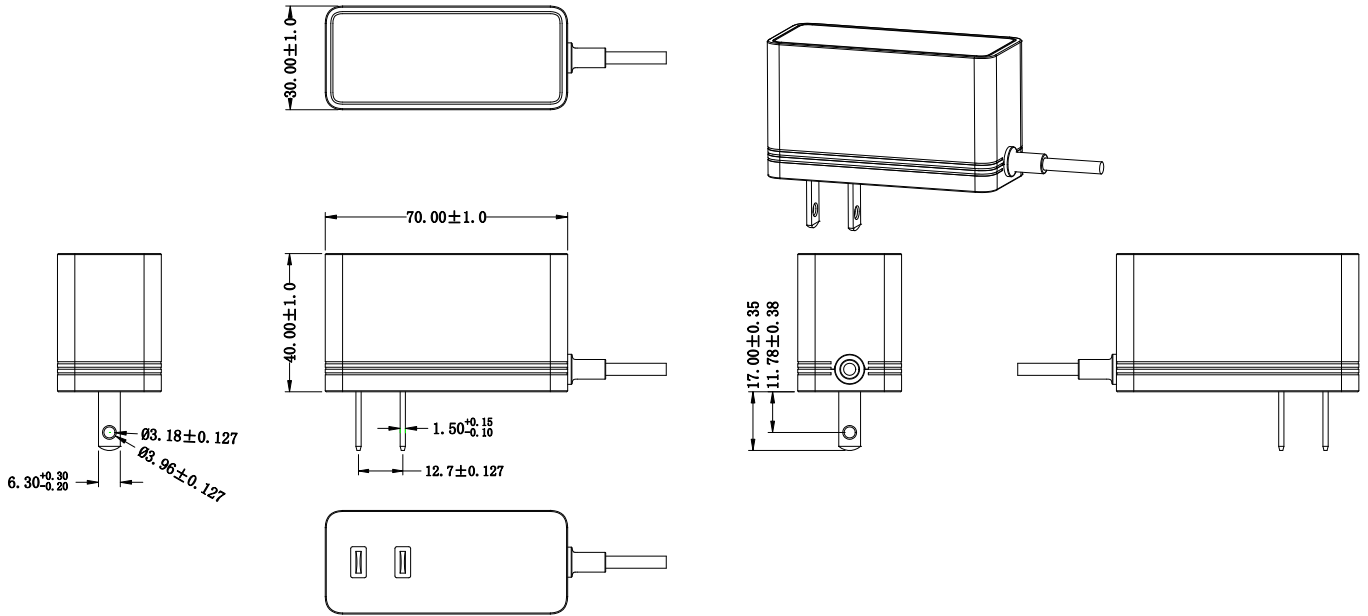

- NOTE: 1. Case cover & chassis material:
PC WHITE(WT-07) (NO KTEC)
2. AC PIN MATERIAL: BRASS (NI PLATED)
3. PAHS 6P NP REACH ROHS PROP65
4. Satin Finish
5. Top mold:MSS017055; Bottom mold; MSS017061

TITLE:		REVISION: A	DRAWING NO.:	
PREPARED :余国娟	CHECKED: 林学贤 林英青	APPROVED : 贺洪明	DATE: 2024-05-21	PAGE: 8 OF 11



KTEC 冠德國際科技
KTEC GLOBAL CO., LTD.

Switching power supply specification(class B)

KTEC P/N:	PRODUCT NO.:	CUSTOMER P/N:
KSA-18W-120150VU	KS240392	

8 NAME PLATE:

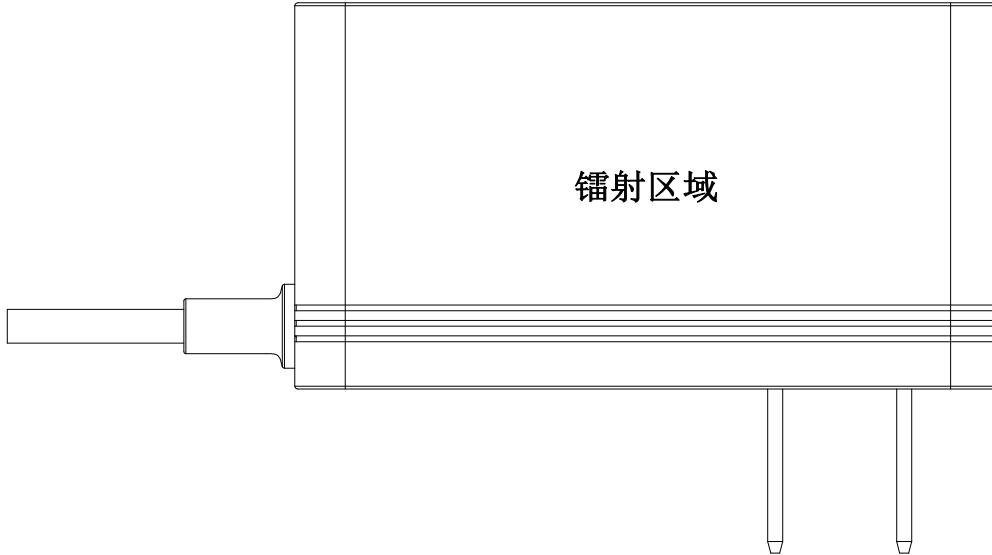

R1,5

KTEC	AC ADAPTOR	PXXYY
MODEL:KSA-18W-120150VU		
INPUT:100-240V~ 50/60Hz 0.5A		
OUTPUT:12V --- 1.5A --- ---		
MADE IN CAMBODIA		
		80CD E215890 POWER SUPPLY

28.5±1

58.5±1

Note: . Laser 鐳射

Date code (PXXYY: P=PAHS,6P,NP, XX=WEEK, YY=YEAR)

TITLE:		REVISION: A	DRAWING NO.:	
PREPARED :余国娟	CHECKED: 林学贤 林英青	APPROVED : 贺洪明	DATE: 2024-05-21	PAGE: 9 OF 11

9 DIMENSION OF OUTPUT PLUG & DC CORD (Unit: mm)

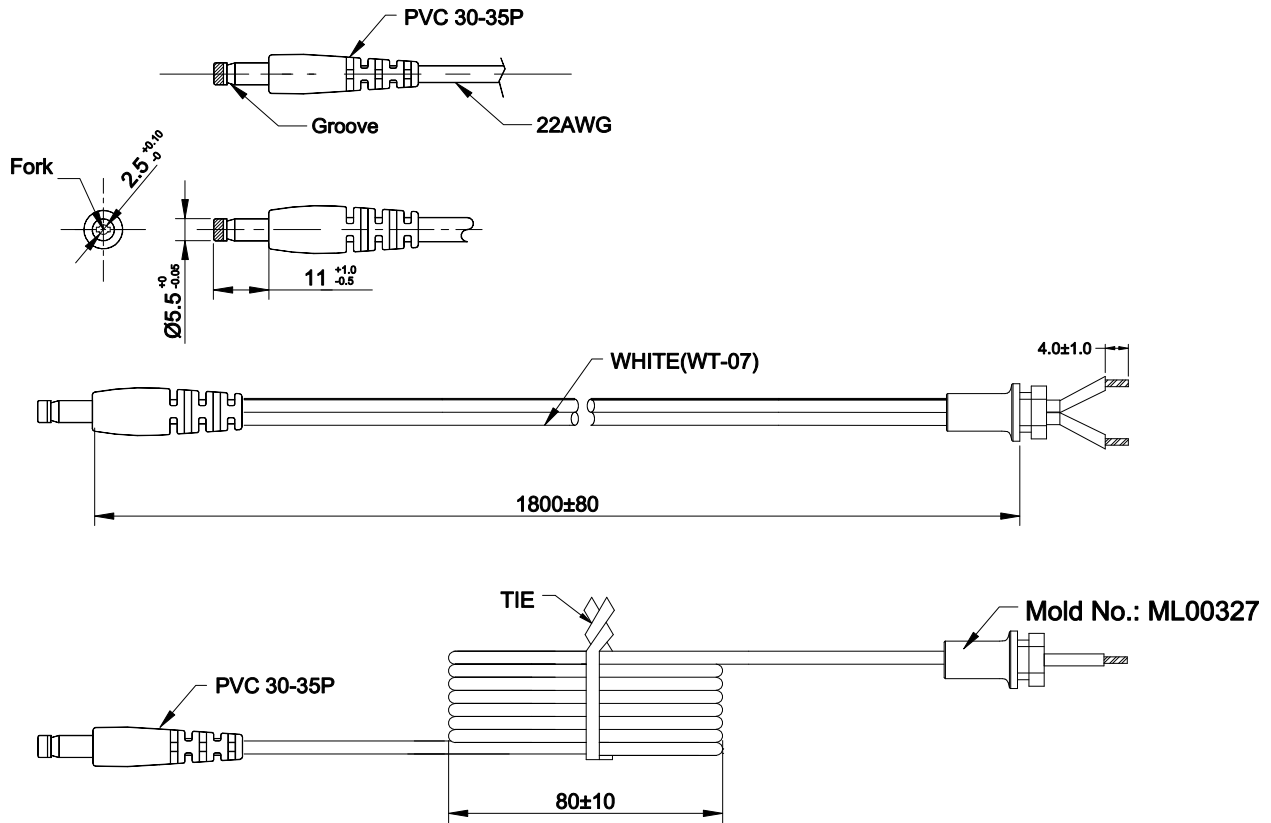

NOTE: (unit:mm)

- 1).WIRE TYPE:VW-1 2468 80°C 300V L=1800mm 2C 22AWG WHITE(WT-07)
BLACK and WHITE----Positive WHITE----Negative
- 2).THE POLARITY:
- 3).PAHS+REACH+6P+NP+ROHS+PROP65

TITLE:

REVISION: A

DRAWING NO.:

PREPARED :余国娟

CHECKED: 林学贤 林英青

APPROVED : 贺洪明

DATE: 2024-05-21

PAGE: 10 OF 11



KTEC 冠德國際科技
KTEC GLOBAL CO., LTD.

Switching power supply specification(class B)

KTEC P/N:

PRODUCT NO.:

CUSTOMER P/N:

KSA-18W-120150VU

KS240392

10 PACKING (Unit: mm)

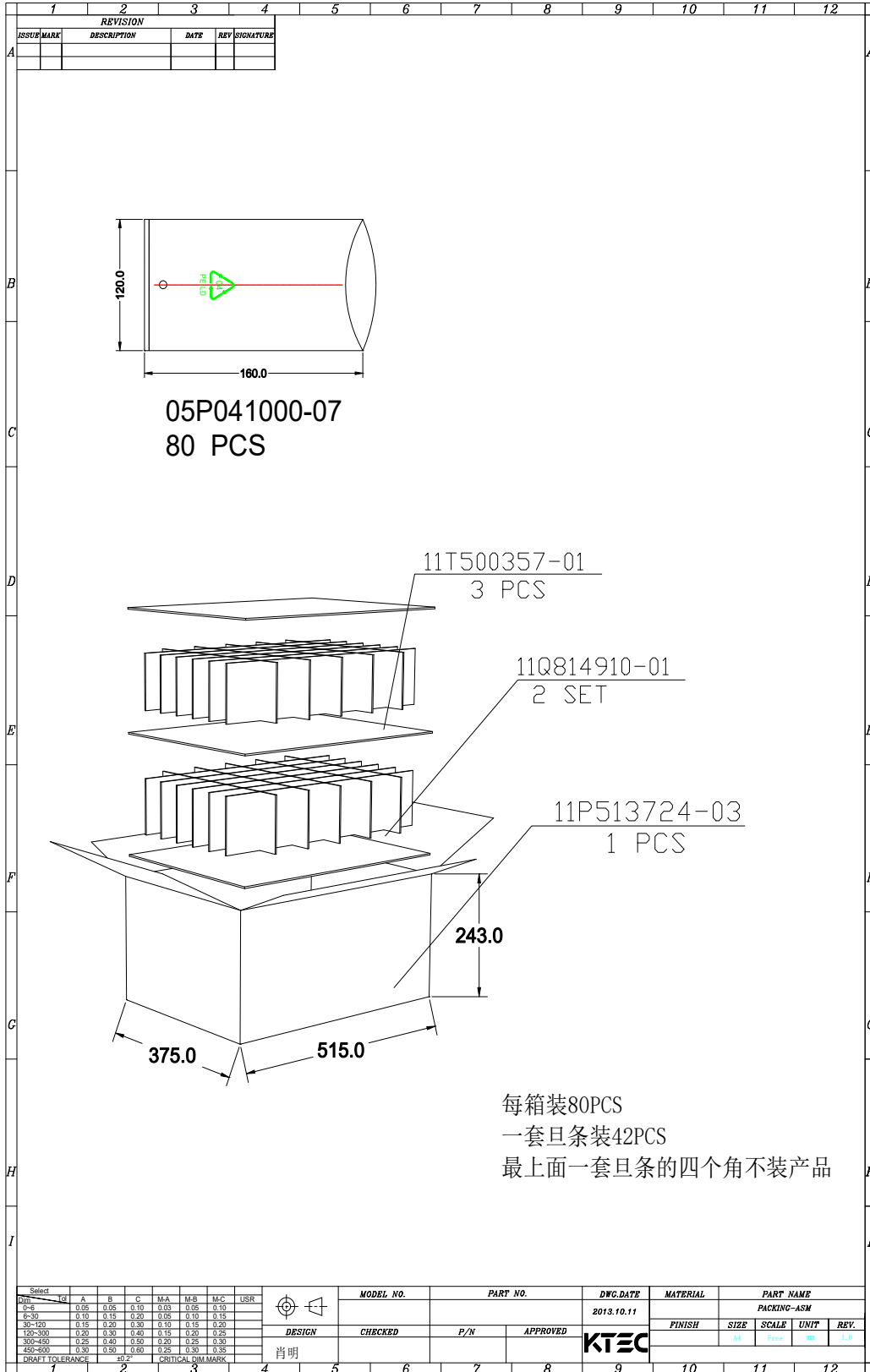

TITLE:

REVISION: A

DRAWING NO.:

PREPARED :余国娟

CHECKED: 林学贤 林英青

APPROVED : 贺洪明

DATE: 2024-05-21

PAGE: 11 OF 11

